

VSD

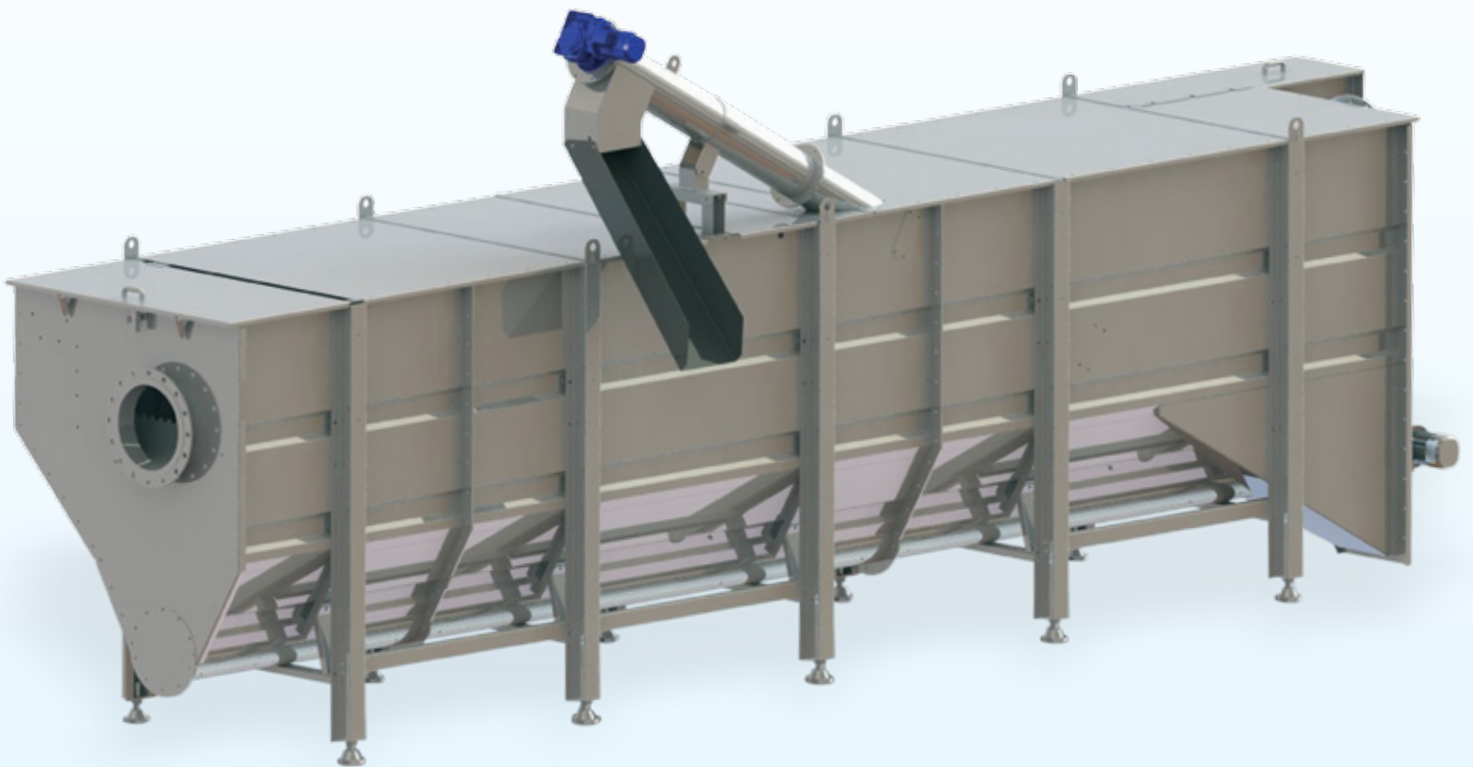

**IMPIANTO COMPATTO
PER RIMOZIONE E LAVAGGIO SABBIE
COMPACT SYSTEM
FOR SAND REMOVAL AND WASHING**

VSD - IMPIANTO COMPATTO PER RIMOZIONE E LAVAGGIO SABBIE

È una macchina combinata atta a svolgere simultaneamente due funzioni:

- rimozione e lavaggio sabbie
- disoleatura e dregassatura

Il refluo viene immesso nella macchina attraverso una tubazione fissa e decanta nella vasca; le sabbie sono quindi rimosse da un sistema di coclee, mentre i grassi e gli oli superficiali sono rimossi dal sistema di disoleatura che prevede l'influssaggio di aria.



VSD - COMPACT SYSTEM FOR SAND REMOVAL AND SAND WASHING

Combined machine able to perform two functions simultaneously:

- *removal and grit*
- *Oil removal/degreasing*

The effluent is fed to the machine through a fixed pipe and decants in the tub; the sands are then removed by a system of augers, while fats and oils surface are removed from the system of deoiling, by an air bower.





TABELLA DIMENSIONALE / DIMENSION TABLE

	PORTATE/FLOW RATE L/sec	A mm	B mm	C mm	D mm	E mm	G mm	W mm	INLET OUTLET PN10	OUTLET GREASE mm
VSD 10	10	4000	2400	1400	1100	1325	3000	1270	DN200	250x150
VSD 20	20	5500	2400	1400	1100	1325	4500	1270	DN200	250x150
VSD 30	30	7000	2400	1400	1100	1325	6000	1270	DN250	250x150
VSD 45	45	7000	3300	1900	1600	1700	6000	1420	DN250	250x150
VSD 60	60	7000	3300	1900	1600	1700	6000	1420	DN300	250x150
VSD 80	80	8500	3300	1900	1600	1700	7500	1420	DN350	250x150
VSD 100	100	11320	3300	1900	1600	1700	10500	1420	DN400	250x150
VSD 120	120	13000	4100	2470	2265	1700	12000	2060	DN450	250x150
VSD 150	150	16000	4100	2470	2265	1700	15000	2060	DN500	250x150

TABELLA POTENZE INSTALLATE / INSTALLED POWER TABLE

		VSD10	VSD20	VSD30	VSD45	VSD60	VSD80	VSD100	VSD120	VSD150
K1	kW	0,55	0,55	0,55	0,55	0,55	0,55	0,55	0,75	0,75
K2	kW	0,37	0,37	0,37	0,37	0,37	0,37	0,37	0,37	0,55
K3	kW	0,25	0,37	0,37	0,37	0,37	0,37	0,37	0,37	0,37

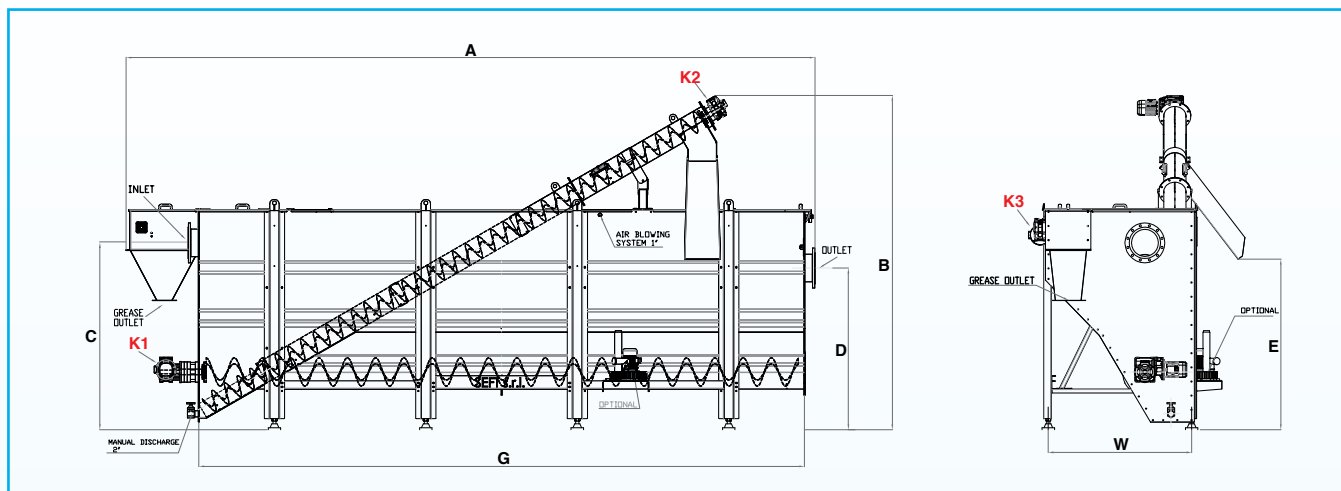
le motorizzazioni possono variare in base alla configurazione di macchina
based on machine configuration, motor power could be different



SEFT S.r.l.

Via Aperte, 195 - 41038 San Felice sul Panaro (MO) - Italy

tel. +39 0535 84544 - fax +39 0535 85585

e-mail: seft@seft.it PEC: seftsrll@legalmail.it

www.seft.it